

250kW Wood Chip Boiler

Loyton Lodge, Devon. Case Study 2



Loyton Lodge is a leisure facility near Bampton, in Devon. The owners are long-time farmers and landowners in the area. Driven by the need to diversify their business in the aftermath of the UK foot and mouth disease in 2001- 2002, and European-wide agricultural reforms reducing subsidies available, the owners decided to create a leisure facility catering for outdoor pursuits. Completed in May 2004, the complex can provide accommodation and catering for more than 20 guests and is heated by a 250kW Binder wood boiler.

The option of wood heating as an alternative to oil was an attractive one as the farm has a significant acreage of woodland. It also fits well with the green image the owners wanted for the new leisure business. The wood chip fuel is provided by the regional organisation South West Wood Fuels Ltd (SWWF).



Wood Energy Ltd
Design, Installation & Service of
Wood Fuelled Heating Systems

How it Works

The Loyton Lodge system uses a Binder 250kW automatic wood boiler, alongside a 135kW back-up oil boiler. The boiler is fed from an automatic auger and fuel store system next door. The fuel store is set into a natural earth bank and chips are delivered at a moisture content of around 25% from a normal agricultural tipper-trailer using gravity feed. During the heating season the boiler is expected to need 50m³ (around 10 tonnes) every 5 to 7 weeks. As well as the Lodge, the wood heating system provides space and water heating for three family homes and a village hall via a simple mini-district heating network.

The system is designed to provide significant volumes of hot water for guests. A 3000 litres insulated water tank is always kept topped up and hot. Even in the case of the tank being drawn down as guests return from a day's outdoor activities, the system is programmed to re-heat the hot water as a priority. It can reheat the whole water tank from a standing start in less than 30 minutes.



Maintenance

The boiler requires de-ashing every 7-10 days, depending on usage and the type of fuel. Maintenance is required twice a year, including de-ashing of the heat exchanger tubes and cyclone. Every 4000 hours the auger motor gearbox oil requires replacement.



Technical Details

Boiler	1 x Binder - RRR/F 200-350
Rated Heat output	250kW
Fuel moisture content	< 35%
Fuel particle size	G30 wood chip specification
Approximate fuel use	170 tonnes per year
Building size	12m x 5.5m x 3m (l x w x h)
Chip store volume	75m ³
Power Supply	3 phase 30Amp
Carbon savings	150 tonnes CO ₂ /year

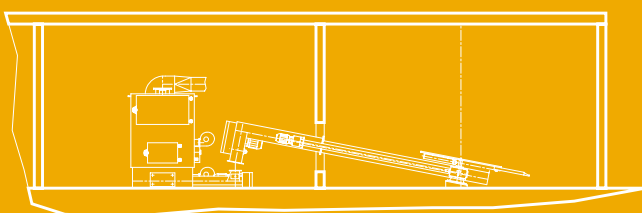

System Side View

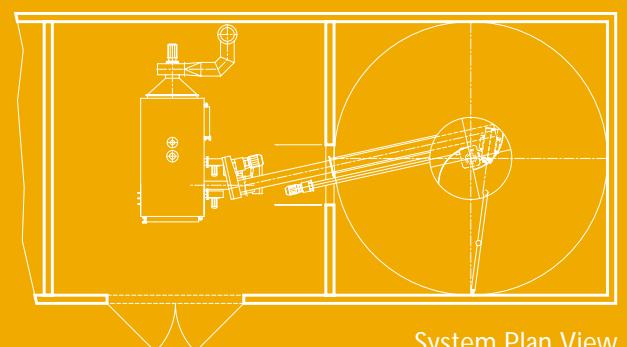

System Plan View